

Rollshutter Installation Instructions

If nothing else, at least read this page!

The source of most problems is related to the installation rather than the product. It is essential to follow the installation guidelines. We urge installers to take the time now to read the instructions and avoid costly, time-consuming problems later. It is only necessary to read through a small fraction of this booklet as it covers all types of Rollshutter installations. At the beginning of each section the booklet will point out if the section can be skipped.

We hope that this installation guide is easy to use. Should you discover an error or an omission please tell us about it. Parts and options change continually so we are updating all the time.

Should you require any support or have any questions, please call us from site: 800-665-5550
(M-F 8am to 4:30pm PST)

We thank you for putting your trust in us.

Sincerely,

Your Talius Customer Service Team



Contents

Section 1	■ Opening Criteria
Section 2	■ Mounting Methods
Section 3	■ Preparation for Through Wall Operator Applications
Section 4	■ Pre-Drilling Guide Rails
Section 5	■ Mounting Rails and Panel Box
Section 6	■ Installing the Operator
Section 7	■ Hanger Installation
Section 8	■ Stopper Installation
Section 9	■ Loading Curtain Into Guide Rails
Section 10	■ Attaching Curtain to Shaft
Section 11	■ Activating Stoppers
Section 12	■ Installing Sill
Section 13	■ Limit Setting for Motorized Operators
Section 14	■ Lock Installation
Section 15	■ Finishings
Appendix 1	■ Safe Rail Servicing

RECOMMENDED INSTALLATION TOOLS AND MATERIALS

Each Rollshutter installation requires a minimum of 2 installers. Not all installations are the same. While the following items will not be required on every installation, this is a list of minimum requirements that we recommend for the majority of Rollshutter installations. While we do not supply common tools and hardware, contact us to purchase the specialized tools like motor tester cables.

① **Talius does not supply the fasteners for installation. We believe this is better handled by the Talius Dealer, based on the on-site construction considerations.**

- Level 4', tape measure, markers
- Cordless drill, indexed drill bit set
- Full screwdriver set, multi-driver set
- Needle-nose pliers, regular pliers
- Allen key set (metric)
- Rivet gun, variety of spare rivets
- Hacksaw, razor knife
- Extension cords, cleansers, rags
- Wood and concrete chisels, hammer
- Tin snips, file
- Side cutters, wire strippers
- Masonry drill or ½" hammer drill
- Long Ø½" (13mm) and Ø¾" (19mm)
- Drill bits
- Block of wood
- 035-.040"(0.9 - 1.0mm) feeler gauge
- Caulk gun, caulking and sealants
- Putty knife
- Spare screws
- Tubular motor limit combs / adjusters
- Electrical tape, masking and duct tape
- Short and tall ladders, tool pouch
- Spare lag bolts, masonry anchors

Available from Talius:

- Plastic caps for screw holes
- Touch-up paint and brushes: brown, white, silver, beige, and black
- Ø8.5mm/Ø5mm step drill bit
- Ø10mm/Ø5mm step drill bit
- Tubular motor tester cable

Parts Overview

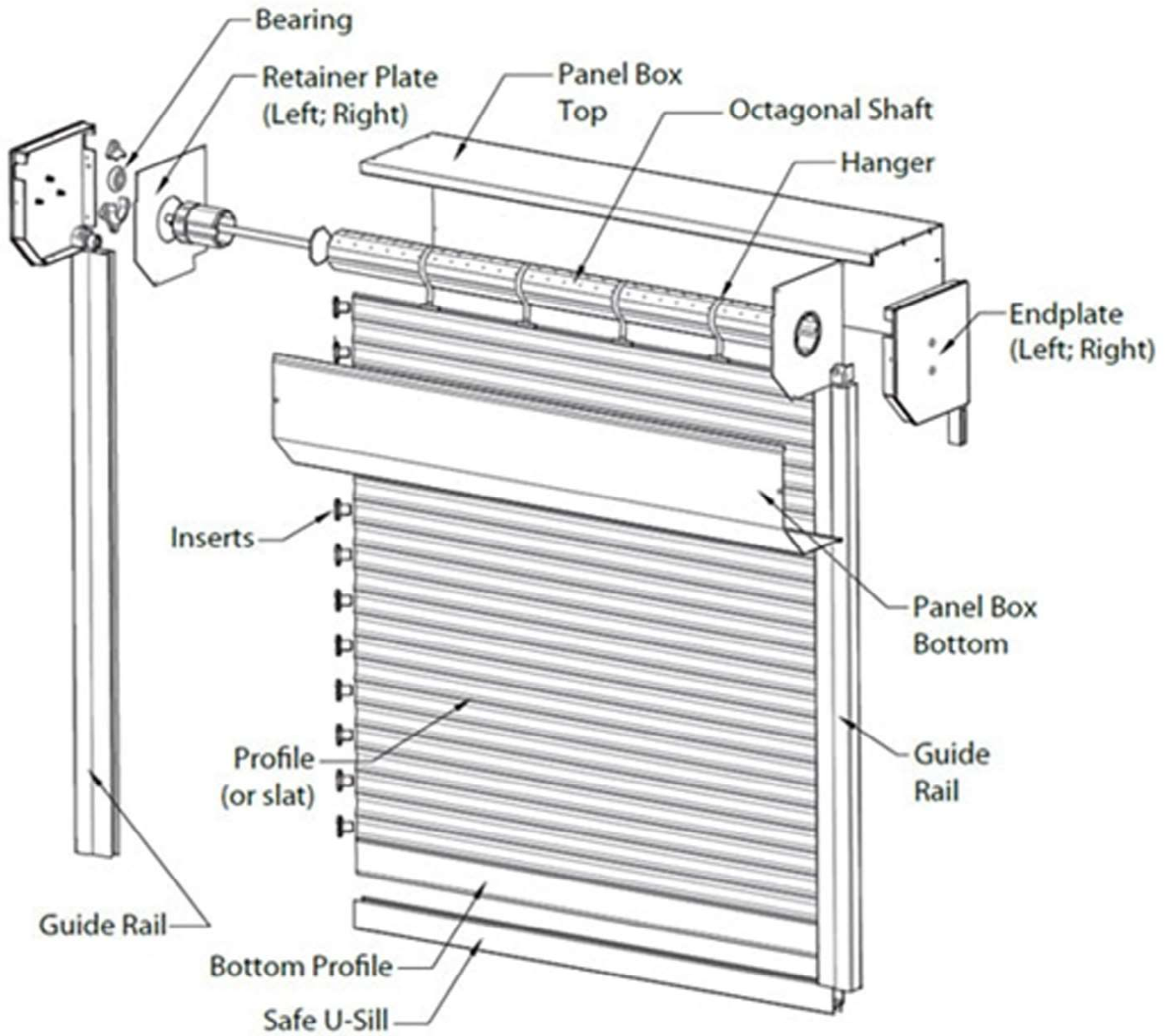

Curtain = Sum of all parts

Guide Rails

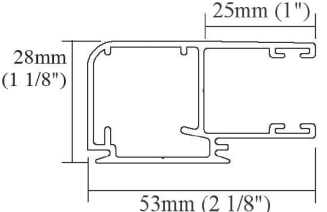
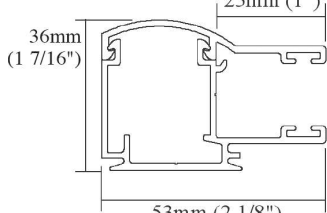
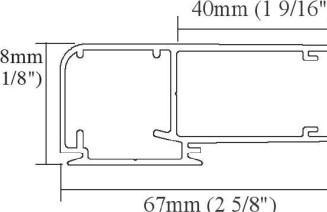
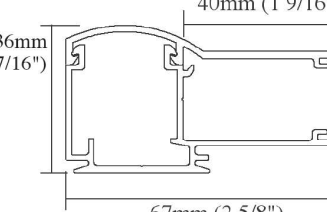
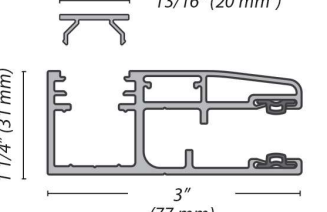
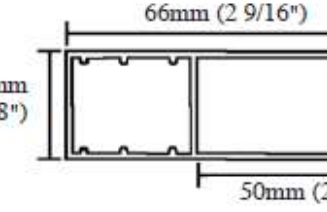
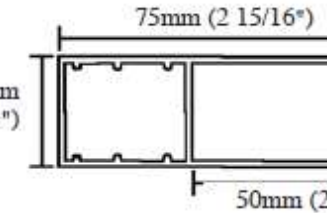
<p>Pro</p> <p>Includes ¼" (6.5mm) build-up</p> <p>For curtain widths under 6' (1.83m) on general exterior applications, and for widths under 10' (3.05) on general interior applications. For applications requiring increased security or wind protection select the PRO-40 or SAFE-40 guide rails</p>	
<p>Safe</p> <p>Includes ¼" (6.5mm) build-up</p> <p>For curtain widths under 6' (1.83m) on general exterior applications, and for widths under 10' (3.05) on general interior applications. For applications requiring increased security or wind protection select the PRO-40 or SAFE-40 guide rails</p>	
<p>Pro-40</p> <p>Includes ¼" (6.5mm) build-up</p> <p>For increased wind load protection. Should generally be chosen when curtain widths exceed 6' (1.83m) on exterior applications, and for widths over 10' (3.05m) on interior applications.</p>	
<p>Safe-40</p> <p>Includes ¼" (6.5mm) build-up</p> <p>For increased security and wind load protection. Should generally be chosen when curtain widths that exceed 6' (1.83m) on exterior applications, and for widths over 10' (3.05m) on interior applications.</p>	
<p>SafeGuard</p> <p>For maximum security and maximum wind load protection. Should be chosen when the application requires the strongest security solution possible or if the application is in a windy location.</p>	
<p>GRM-66</p> <p>For use with SAFE View rollshutters with a B1 (guide rail height) of up to 67" ONLY.</p>	
<p>GR-75</p> <p>For use with all SHIELD Standard rollshutters.</p> <p>For use with SAFE View rollshutters with a B1 (guide rail height) of over 67".</p>	

Section 1

OPENING CRITERIA

Ensure that the opening is square and level. The Rollshutter must be mounted as follows:

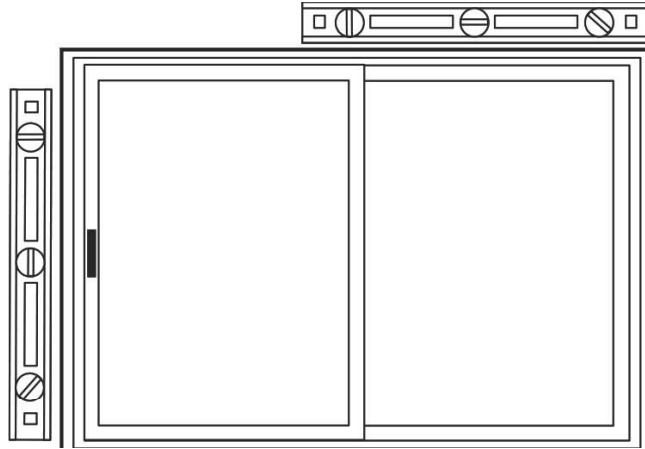

1.1) Panel Box and Shaft

The shaft must be level. If the shaft is not level the Rollshutter curtain will travel to one side and will break apart at the shaft's highest point over time. Note that the shaft is not necessarily aligned perfectly with the panel box.

1.2) Guide Rails

Both guide rails must be vertically mounted. If they are not, the Rollshutter curtain will either rub inside the guide rails or come out of the guide rails.

1.3) Sill

The sill or floor may have a deflection from the horizontal by 1/100 of the width to a maximum of 1 1/2" (30mm). This is the most forgiving place for a Rollshutter to adjust to an imperfect installation. If the sill or floor is not level, ensure that the guide rails are cut to uneven lengths to take up the difference in the floor or sill while leaving the panel box and shaft level.

Section 2

MOUNTING METHODS

Insert the panel box endplate legs (or rolling door brackets) temporarily into the guide rails.

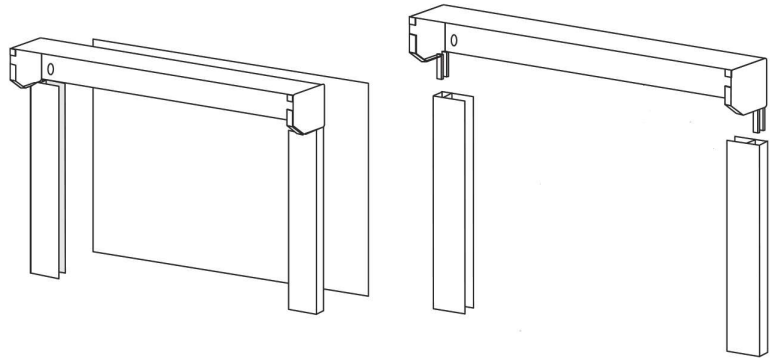

2.1a) Face of Wall Mounting

Hold the unit against the opening and determine the future fit. It is important to ensure that there is an even plane on which to mount the Rollshutter. The build-up is recommended to be at least 1 3/8" (35mm) wide along the required areas in order to provide stability. In the case of wider rails like the SV-75, Aluminum tubing with a width of 2" is recommended. Various extruded build-up materials can be used to achieve such an even surface. This build-up may be purchased from Talius and if that is the case it will be included with your product.

Choice of Height Combinations:

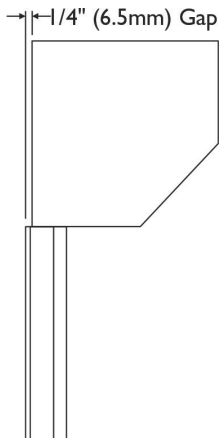
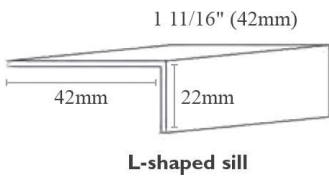
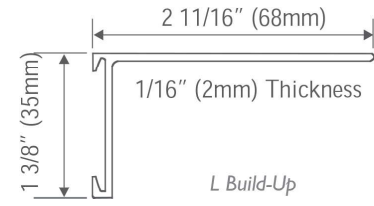
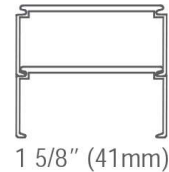
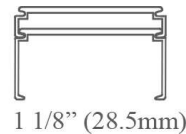
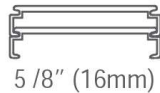
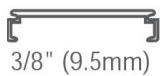

i The PRO guide rails already incorporate aluminum build-up of 1/4" (6.5 mm) and the backs of these rails are not in line with the panel box.

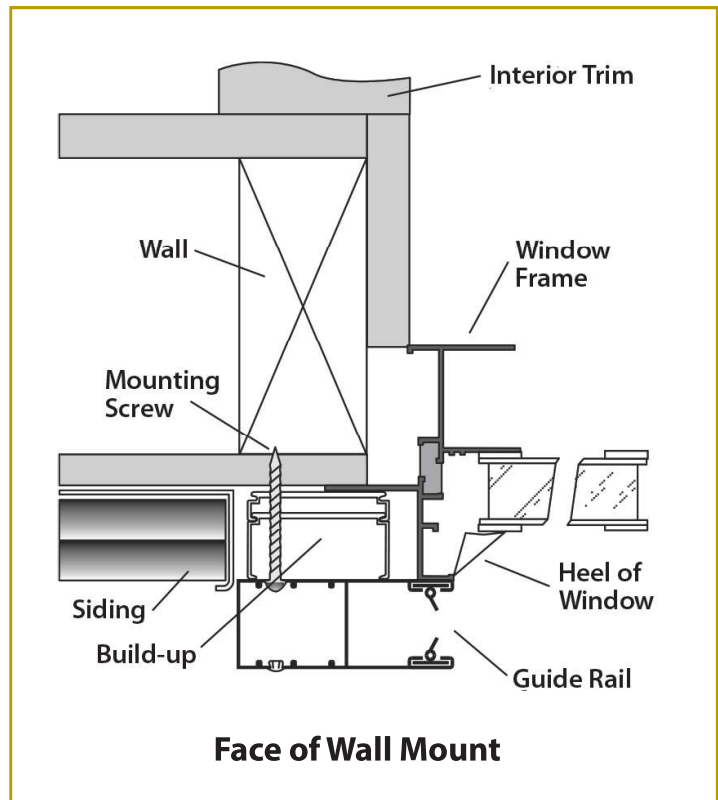

Section 2 (Continued)

2.1b) **Between Jamb, Under Lintel Mounting**

If the Rollshutter will be installed inside an opening rather than on a surface, hold the unit inside the opening and determine its fit. The prime concern will be to stay level, plumb, and square. Many openings are not true and level so it may be necessary to use build-up materials such as wood shims to fill out any gaps. Talius does not supply such build-up materials.

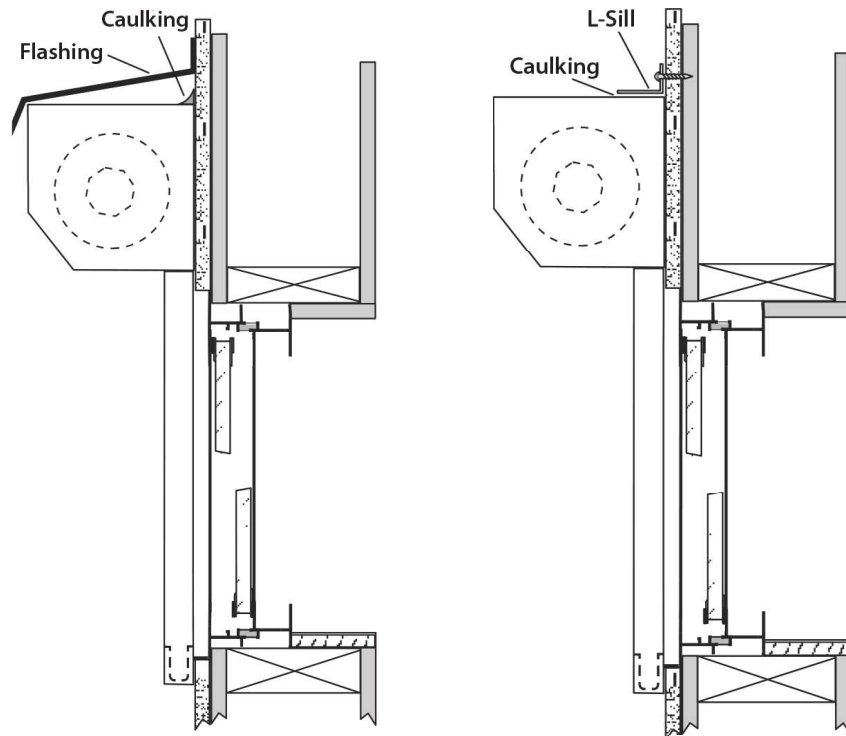

For some face of wall applications we suggest flashing to prevent water build-up behind the Rollshutter. Talius does not supply traditional flashing material but L-sill can be used in its place if needed

Section 3

PREPARATION FOR THROUGH-WALL OPERATOR APPLICATIONS

In this section, determine how the operator exits the Rollshutter and interacts with the surrounding wall. If the operator does not penetrate a wall, ignore this section.

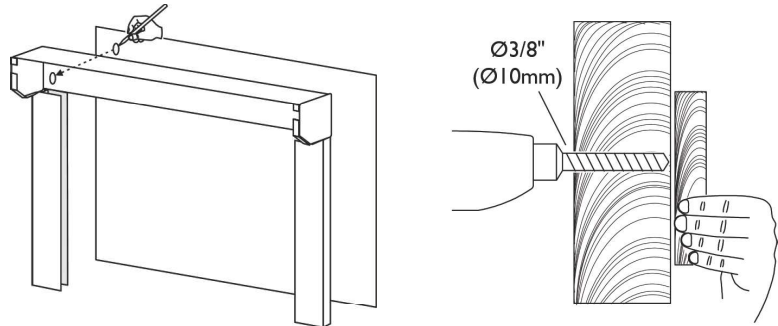

3.1.a) Tape Operator (all types)

If the control tape will travel through a wall look for an exit hole of approximately $\text{Ø}1''$ ($\text{Ø}25\text{mm}$) in diameter in one of the lower back corners of the panel box. Hold the panel box and rails against the opening and mark the location of the hole on the opening. On the marked location drill a pilot hole of approximately $\text{Ø}3/8''$ ($\text{Ø}10\text{mm}$) in diameter horizontally through the wall. Have a helper safely hold a piece of wood over the location the hole will exit the interior wall. Once the pilot hole is satisfactory, increase the diameter to $\text{Ø}3/4''$ ($\text{Ø}20\text{mm}$). The hole can angle up or down somewhat, but it should allow very little side-to-side movement.

3.1.b) Crank Rod Operator with Gear or Manual Override Motor

If the job consists of several units it is important to be aware that there are various gears and/or manual override motors that require different sized connectors. For example there are 6x6mm and 7mm hexagonal connectors that look rather similar. If the job contains different sized connectors, push each one into a gear or manual override motor until each connector is matched up satisfactorily to a Rollshutter unit before proceeding with this section. On the marked location, drill a pilot hole of approximately $\text{Ø}3/8''$ ($\text{Ø}10\text{mm}$) in diameter through the wall. Have a helper safely hold a piece of wood over the location the hole will exit the interior wall. The drilling must be performed at the pitch that was previously determined. Once the pilot hole is satisfactory, increase the diameter to $\text{Ø}1/2''$ ($\text{Ø}13\text{mm}$). The hole must be straight and allow no side-to-side movement.

If the connector rod of the universal will travel through a wall, look for an exit hole of approximately $\text{Ø}1''$ ($\text{Ø}25\text{mm}$) diameter in one of the corners of the panel box. Hold the panel box and rails against the opening and mark the location of the hole on the opening. Then insert the connector rod and universal through the back of the panel box into the gear or manual override motor and note the pitch of the rod. The pitch will often be somewhere between horizontal to 45° downward.

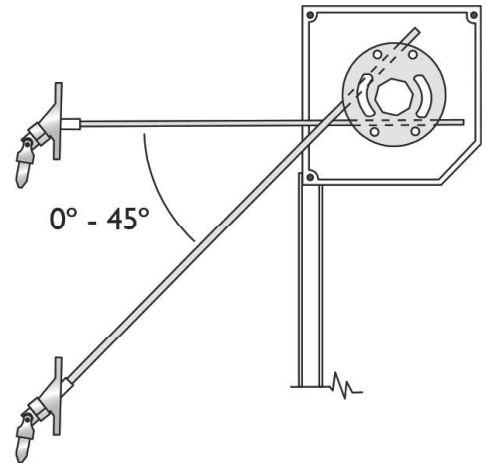

3.1.c) Torsion Spring Operation

Proceed to Section 4.

3.1.d) Motor Operator

An exit hole for the power cable of approximately $\text{Ø}3/4''$ ($\text{Ø}19\text{mm}$) will need to be drilled in one of the back corners of the panel box. The hole is not drilled at the factory because of site variation. Remove the lid and look for the motor side. Proceed to drill a hole of desired size and location within the panel box endplate. Hold the panel box and rails against the opening and mark the location of the hole on the opening. An electrician should cover any cable exiting the panel box with a sleeve to prevent cutting of the wires by the endplate. On the marked location the electrician will drill a hole of approximately $\text{Ø}3/8''$ ($\text{Ø}10\text{mm}$) diameter horizontally through the outer layer of the wall. The electrician will later run the wires through the inside of the wall into the hole at the back of the panel box. If the Rollshutter contains a manual override then also follow section 3.1b on crank rod operators.

Section 4

PRE-DRILLING GUIDE RAILS

If you have ordered your rails with pre-drilling, by-pass this section.

The guide rails are the main supports that hold up a Rollshutter unit and will later need to be fastened securely. When drilling through two layers of aluminum the hole through the outer layer must be $\text{\O}8.5\text{mm}$ ($\text{\O}11/32''$) precisely for the screw caps, or $\text{\O}10\text{mm}$ ($\text{\O}3/8''$) for screw caps for security or high-wind applications. The hole through the inner layer should be approximately $\text{\O}5\text{mm}$ ($\text{\O}3/16''$). For two-piece safe rails, drill only a $\text{\O}5\text{mm}$ ($\text{\O}3/16''$) hole through one layer – the bottom mount piece. If there are many holes to drill the factory can supply at reasonable cost a step drill bit that drills both holes simultaneously. Normally the holes should be spaced no more than 16" - 20" (40 - 50cm) apart, but for security and high-wind applications the spacing should be 6" - 12" (15 - 30cm). Ensure that the first and last holes are no closer than 3" (75mm) to either end of the guide rail.

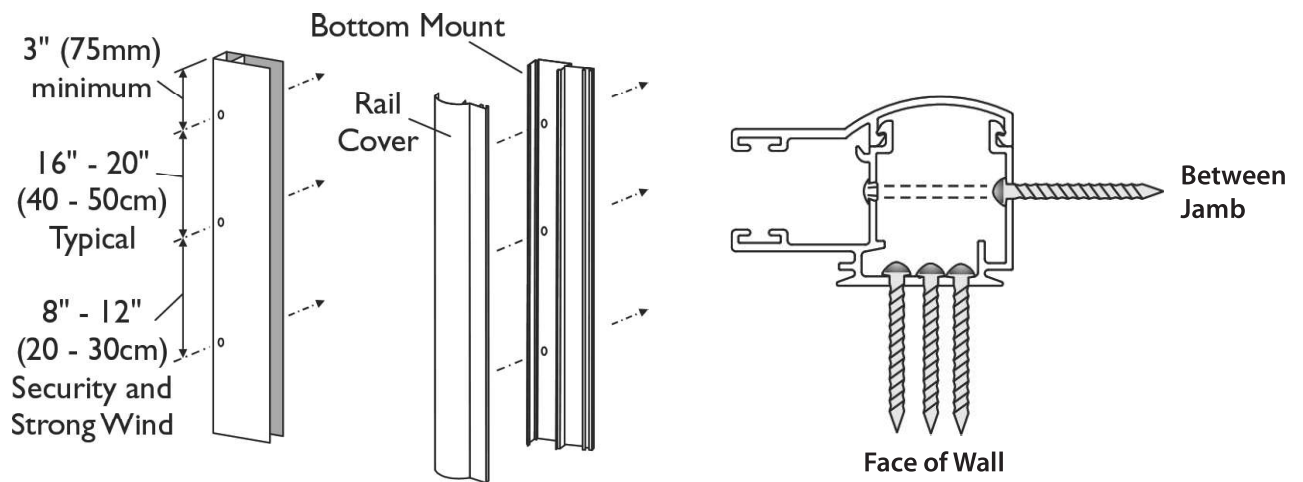

A

If the Rollshutter is equipped with two-piece safe guide rails, pre-drilling is not required, and holes may be drilled in the mounting channel at any location without the concern of being symmetrical with the opposite rail. The example below shows a number of possible mounting locations.

Section 5

MOUNTING RAILS AND PANEL BOX

In this section the framework will be attached to the opening. Note that some guide rails are not symmetrical and carry a removable warning decal showing which end of each guide rail is “up and front”

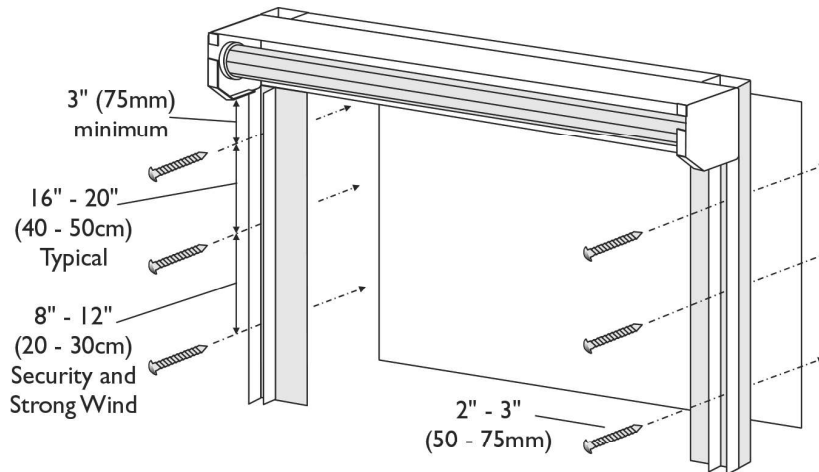

5.1) Guide Rail Mounting

Lift the unit into place being careful to support both the panel box and guide rails to ensure you do not break the leg of the end plate. Position and hold the unit over the opening where you wish it to be located. Install the top screw in one of the guide rails. Using a 4' level and ensuring the bubble is perfectly centered between the lines, level the box and shaft and install the screw into the top hole of the opposite guide rail. Again, using the level to ensure the rail is plumb, install a screw first in the bottom of one guide rail before installing the remainder of screws in this guide rail. Before continuing to install the second rail, measure to ensure that the width of the opening between the rails is the same distance at the top, middle, and bottom of the rails. In the case of between jamb installations, you may have to shim the guide rails to get them plumb and parallel from top to bottom. In the case of Safe Rails, the cap can now be snapped onto the mount.

Watch out for these conditions

Rollshutter equipped with any automatic, manual or key lock

The guide rails will be modified in some ways, making right and left rail not interchangeable. They will be equipped with notches or some indication attached. Notches for slide locks should always be at the bottom of the guide rail when the framework is attached. Look for a removable warning decal showing which end is “up and front” to ensure that the rails are positioned correctly.

Rolling Doors without Panel Boxes

Align the rolling door brackets with the guide rails. If there are factory-supplied plastic spacer rings slide all of them onto the shaft and then attach the shaft between two rolling door brackets. Hold the framework against the opening as previously planned. Attach it in the opening with the 2"-3" (50 – 75mm) long screws mounted through the pre-drilled screw holes. In case of a rolling door without panel box, attach the brackets to the mounting surface with appropriate fasteners through the mounting flanges on the back of each rolling door bracket.



Section 5 (Continued)

5.2) Panel Box Mounting

To securely fasten the panel box to the mounting surface retainer plate. Slide the retainer plates inwards along the shaft, out of the way. Pre-drill at least one hole in the top back corner of each end plate. Make sure to align with a matching hole in the mounting surface if necessary, such as a masonry anchor in the case of a concrete wall. Secure each end plate with at least one 2" - 3" (50 - 75mm) long screw. For units over 50 lbs (22kg) Rollshutter curtain weight, security applications, or high wind installations, use two fasteners per end plate as shown. Do not over-tighten the screws to avoid any cracking of the die cast end plates. Should a crack be discovered, a replacement end plate must be installed. Secure the panel box top with 2" - 3" (50 - 75mm) long screws spaced 16" - 20" (40 - 50cm) along the top corner. To avoid the possibility of tearing through the sheet aluminum, each screw hole should be reinforced with a large flat washer.

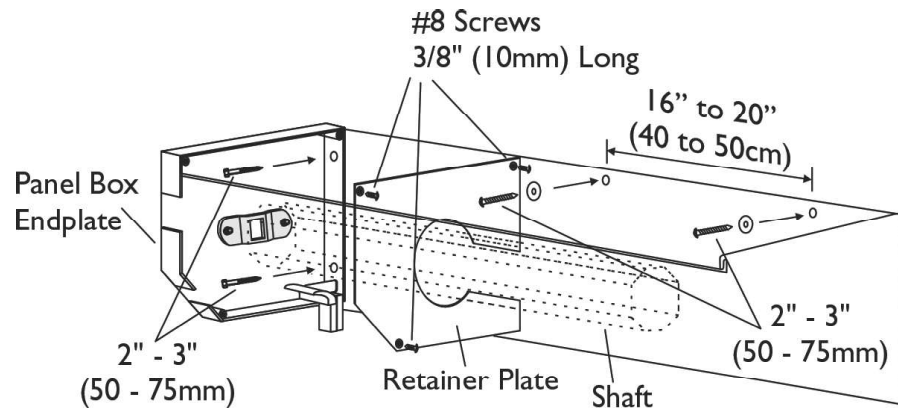

Section 6 • 6.1a

(Continued)

While a helper is feeding the tape from the tape operator, start turning the shaft as if the shutter was rolling in a downward rotational direction. This will result in loading tape onto the tape wheel. Continue until all the tape from the tape box is used up. Then reverse the process and put approximately 18" (50cm) of tape back into the tape operator. This will ensure a few windings so that the end of the tape does not tear off its fastening point inside the operator. If the operator consists of a pull tape operator, place a large flat screwdriver in the tape exit slit or tie a slip knot to prevent the spring from reeling the tape back in again.

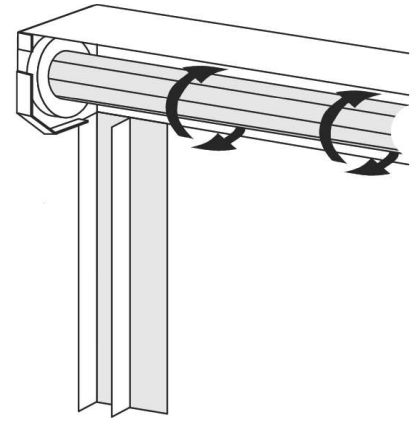

6.1b) Crank Rod Operator

If the operator runs through a wall, insert the universal with the connector through the hole in the wall and ensure that the square connector inserts into the matching slots inside the gear. The connector will be too long. Determine the excess length, remove the universal and cut it down to size with a hacksaw. Reinsert the cut-down connector and attach the universal with two 2"-3" (50-75mm) long screws to the wall. In some cases, at the request of the dealer, the factory will also supply an auxiliary mounting plate to be placed underneath the universal joint to provide a stronger mounting plate.

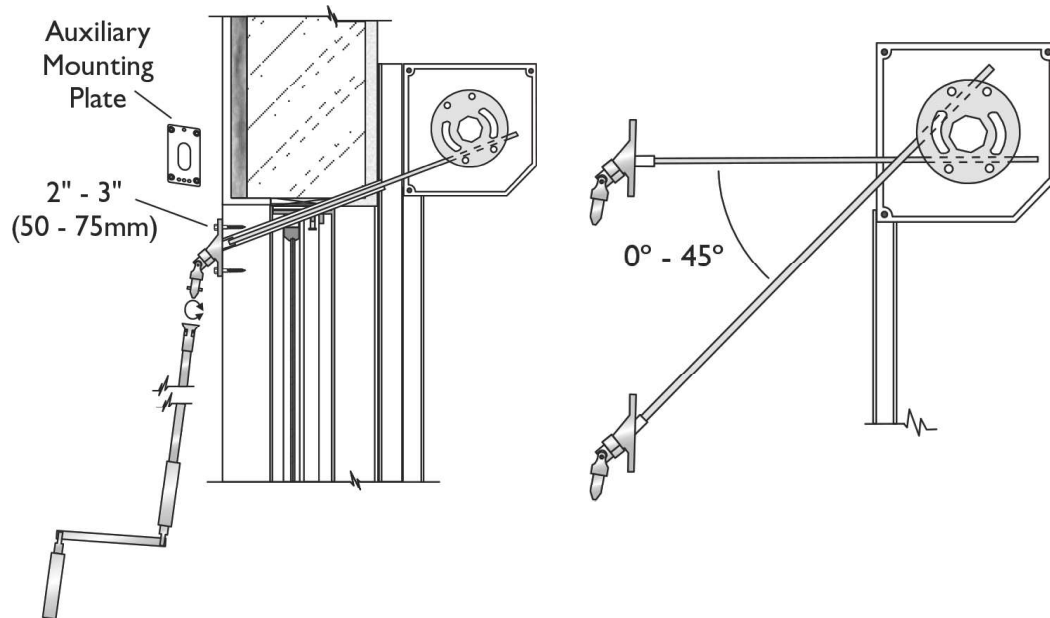

If the operator does not run through a wall the universal joint will be attached directly to the panel box in a similar manner. Most often the factory has already performed this. If the operator is mounted on a rolling door bracket frame, the connector rod is simply pushed into the gear or manual override motor and must be drilled and fastened with a cotter pin.

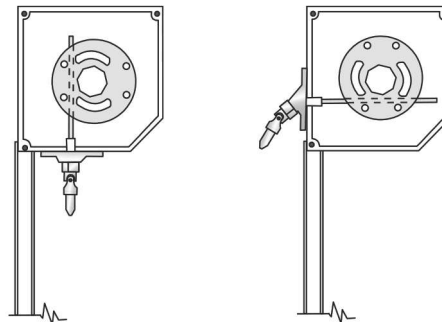

Section 6 • 6.1b (Continued)

Attach the crank rod. Crank rods are supplied in standard lengths of 68 ¼" and may be cut down to a comfortable size. There are two styles of crank rod. The removable crank rod has a bell connector and can be slipped on and off the pin of the universal at any time. The attached crank rod is slipped onto the pin of the universal and attached permanently with the supplied pin and collar. Finally, attach the crank rod holder onto the wall with two appropriate screws. The holder keeps the rod in place when not being used. If the crank was attached to a motor with manual override proceed to Section 7.

Once the crank is attached to a built-in gear, perform the following test to determine the type of gear in the panel box and repeat the test for each Rollshutter in the job. Grab the shaft with both hands and attempt to turn it either way. If the shaft can be moved in just one direction it is an A.B.S. gear (Anti-Block System) and you can proceed to the next section. However, if the shaft cannot be moved at all, it is a gear with a built-in limit. Now turn the crank so that the top of the shaft rotates in the down direction towards the back of the panel box. Continue until it reaches a limit in the gear that prevents any further cranking. Normally the factory has pre-set the shaft rotations so that it is already at or very near the built-in limit. This will later constitute the lower limit of the Rollshutter operation and will prevent anyone from over-cranking the unit downwards.

6.1c) **Spring-Loaded Operation:** Proceed to Section 7.

6.1d) **Motor Operator**

Important Notes

Most tubular Rollshutter motors operate on a voltage of 120 Volts AC or more. In all States and Provinces, regulations require that certified electricians perform all electrical hook-ups. The manufacturer strongly recommends that all regulations be obeyed. Motorized units can be ordered with a variety of switching systems. Wiring diagrams for such systems are available upon request or can be found on mytalius.com. Under no circumstances should the installer deviate from the wiring diagrams and change items or hook-up patterns. Never use any electrical components that were not supplied by the manufacturer. Never connect wires of two or more tubular motors together, unless specifically instructed on certain motor types. Tubular motors are highly specialized units with custom designed switching mechanisms. Even simple looking items are specifically designed for these units. **Any changes will almost certainly result in catastrophic damage!** Over the years we have seen motorized units damaged by electricians who believed they comprehended the principles behind tubular motors. It is very tempting to see a simple design in the motor configuration, but this is wrong. The description supplied with this job does not contain enough information to explain the intricacies of a tubular motor and it cannot be deduced from the components! Finally, it is essential that each Rollshutter dealer own a set of motor tester cables which can be obtained from the factory.

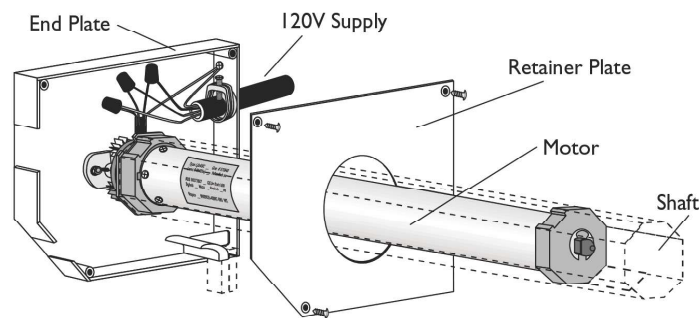

If the motor operator is equipped with a manual override begin by looking up **Section 6.1b** for the installation of the manual override crank rod. In the case of a removable crank and universal, no fastening of the universal or crank is needed. If the panel box endplate is fitted with a metal retainer plate, slide the retainer plate away to allow for clear access to the motor. Hook up the tester cables by matching the colour coded clamps to the coloured wire ends. If a tester cable is not available have the electrician hook up the motor to the switching mechanism as outlined in the wiring diagram. From this point on in the installation it is imperative that the motor is located fully inside the shaft. Especially on rolling doors, ensure that the crown is securely located between the notch in the motor's drum and the shaft. The shaft must be secured so that it cannot slide sideways, which requires that the clamp bolt on the adjustable socket, if so outfitted, is screwed tight while pushing the socket against the end of the shaft. Switch the tester cable so that the top of the shaft turns in the downward direction towards the panel box. Continue until the motor comes to a stop by itself. The shaft has now reached what will later be its lower limit. The factory normally presets the shaft so that it starts out already at or close to the lower limit. Therefore, the motor may not even have operated at all or only for a very brief moment.

Section 7

HANGER INSTALLATION

Unpack the Rollshutter curtain. If the Rollshutter is spring-loaded, count the number of layers in the roll.

Note the number here: _____. This information will be used in section 10.

7.1a) Steel Hangers

Slide the T-shaped metal hangers onto the first profile at the top of the curtain. Use at least one hanger for every 16" (40cm) of width and space them evenly. Similarly, if there are plastic spacer rings on the shaft distribute them evenly as well. Later the hangers will be attached to the shaft between these rings.

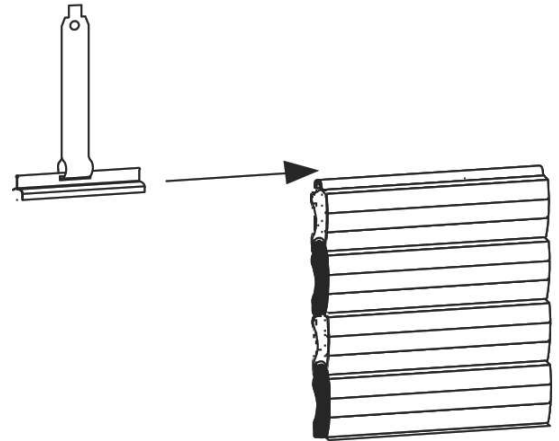

7.1b) Hanger Locks

Slide the Talius hanger locks onto the top profile of the rollshutter curtain, spacing them evenly and no further than 16" in from the end.

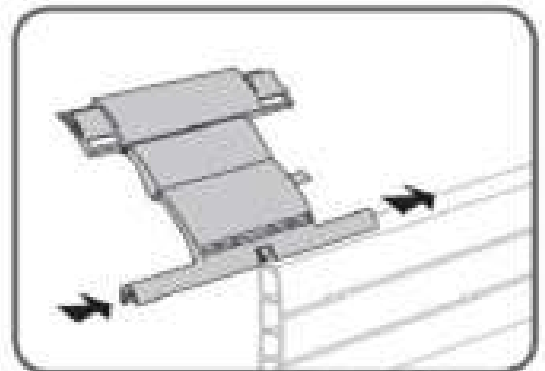

Section 8

STOPPER INSTALLATION

If the Rollshutter unit is motorized there may be no stoppers needed, proceed to next section.

Determine which type of stoppers the factory has supplied. There are two possibilities:

8.1a) **Concealed stoppers with fixed head:**

Insert one on each side of the bottom profile

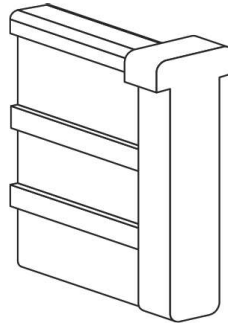

8.1b) **Surface Stoppers**

Drill two holes approximately $\text{Ø}1/4"$ ($\text{Ø}7\text{mm}$) diameter about $3"$ (75mm) from the ends of the bottom profile, close to the top.

Do not install until Section 11.

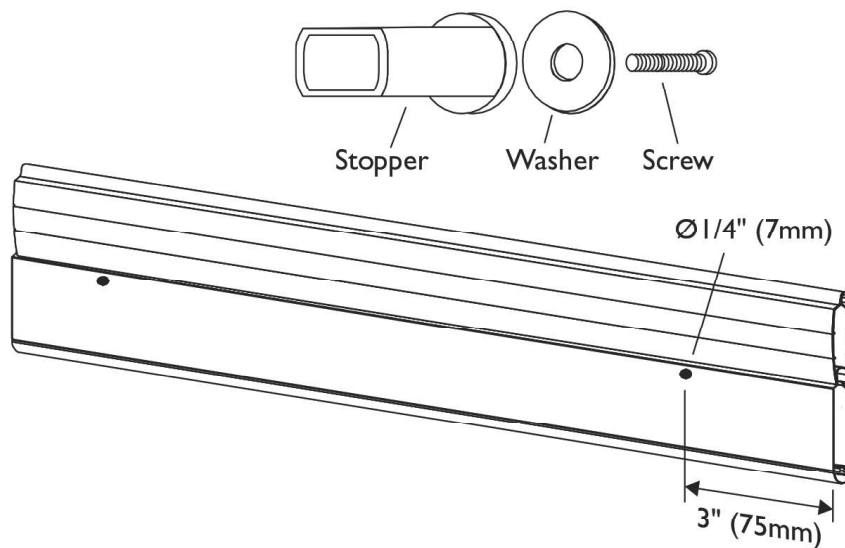

Section 9

LOADING THE CURTAIN INTO THE GUIDE RAILS

If the Rollshutter was supplied with Concealed Stoppers with fixed head and polyguides are installed in the endplates, you must first remove the polyguides. Once this has been done, slide the Rollshutter curtain carefully over the shaft fully into the guide rails. It is recommended to cover the shaft with plastic or cardboard to prevent scratching of the curtain. If there is no natural sill for the curtain to rest on, proceed to Section 12 to install the sill before feeding the curtain over the shaft. Once the curtain has been fully fed into the guide rails, the polyguides must be reinstalled.

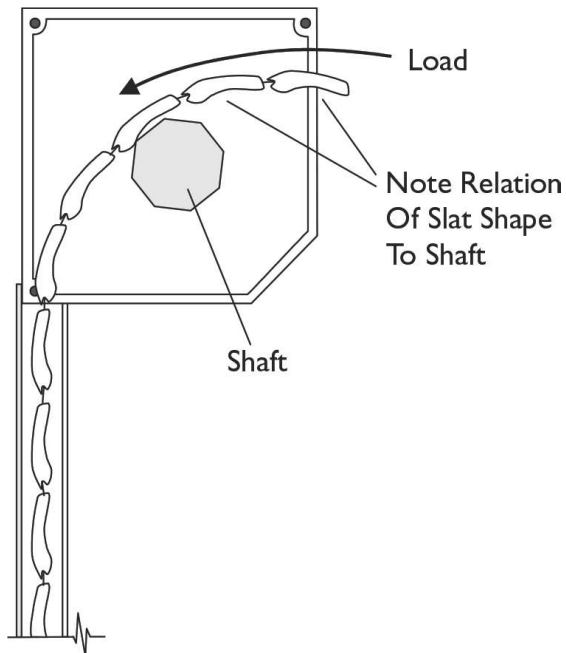

Section 10

ATTACHING CURTAIN TO THE SHAFT

In most cases the Rollshutter will be supplied with an octagonal galvanized steel shaft.

10.1) Spring-loaded

If the Rollshutter is spring-loaded, the spring needs to be pre-loaded now.

If the rollshutter is not spring loaded (torsion spring operated) proceed to 10.2 a or b.

From the relaxed state, turn the shaft (which includes the spring) by hand in the “down” direction by the number of layers that had been previously counted in Section 7 plus one additional turn. Carefully hold the shaft while the hangers are being attached. It is recommended to wear protective gloves that offer superior grip and up to 3 or 4 installers may be needed for this step depending upon the size of the spring.

10.2 a) Steel Hangers

Bend each hanger over from behind the shaft to the front. Slightly twist the end of the hanger so that the square tab-end slides into the narrow, stubby slot on the shaft. This will hold the hangers securely in place.

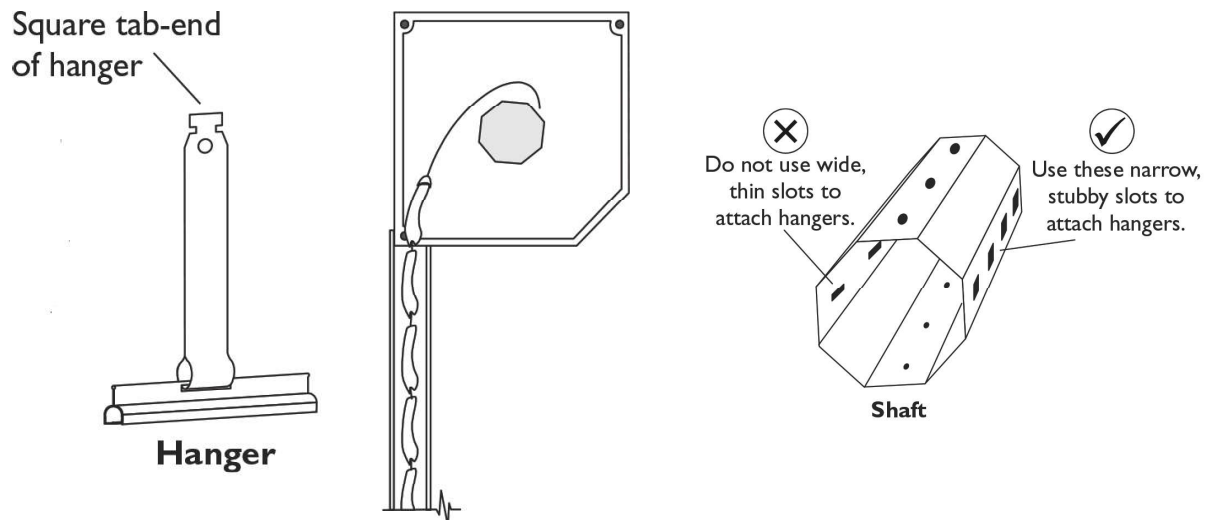

If the Rollshutter is spring loaded, the curtain should now easily roll-up with some manual assistance. It should not fly up abruptly on its own! If this happens detach the curtain hangers, then increase or decrease the pulling strength by preloading the spring more or less, it is recommended to wear protective gloves.

When all the hangers have been installed there should be at least one hanger for every 16" (40cm) of width, spaced evenly. If there are plastic spacer rings on the shaft they should be distributed evenly as well. The hangers should be attached to the shaft between the rings.

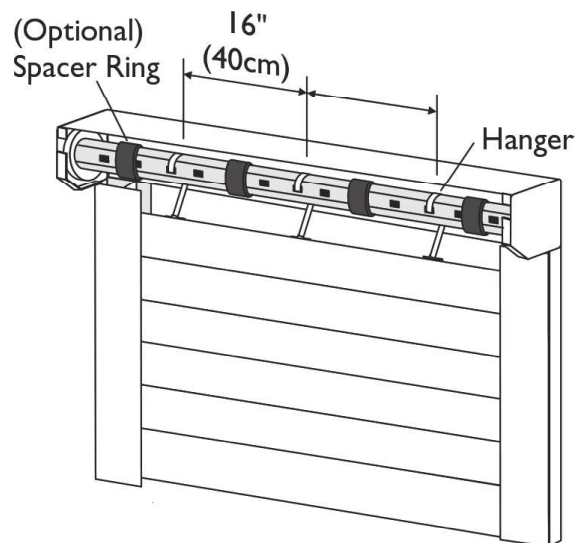

Section 10 (Continued)

10.2 b) Hanger Locks for 40 & 60 mm Shaft Sizes

Place a 2"x4" block at the bottom of the rollshutter resting on the ground of the sill before sliding the entire curtain into the guide rails.

A

Talius hanger locks are shorter than regular hangers. Therefore, you must rest the rollshutter curtain on the 2" x 4" block to ensure that the rollshutter curtain rests higher in the panel box thus giving you easier access the top profile on the rollshutter curtain to attach the Talius hanger locks. Failure to use the 2" x 4" block will result in the curtain sliding further down into the guide rails, thus making it very difficult to attach the Talius hanger locks and affix them to the shaft.

Place the white hanger lock rings over the shaft, one on either side of each hanger lock. The end of the ring with the "hook" on it should be on the back side of the shaft. Clip the hanger lock mounting lug into a rectangular hole in the shaft. Engage the "hook" of the ring into the slot in the rear of the hanger lock, bring the two ends of the rings together and tighten as fully as possible.

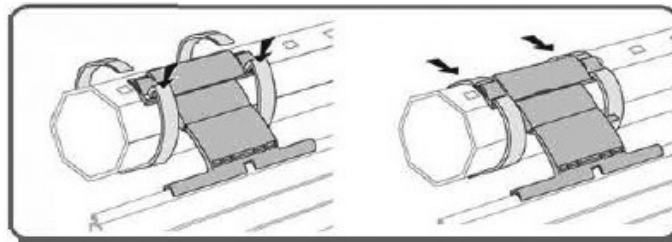

10.2 c) Hanger Locks for 70 mm Shaft Size

Install these hanger locks leaving a minimum X dimension of 30 mm (1 3/16") and a maximum of 80 mm (3 5/32") from the end of the shaft as shown in the diagram below. It is recommended to use one hanger lock per 600 mm (23 5/8") length of octagonal shaft (Y) or per 4Nm (XL: 6 Nm) motor performance.

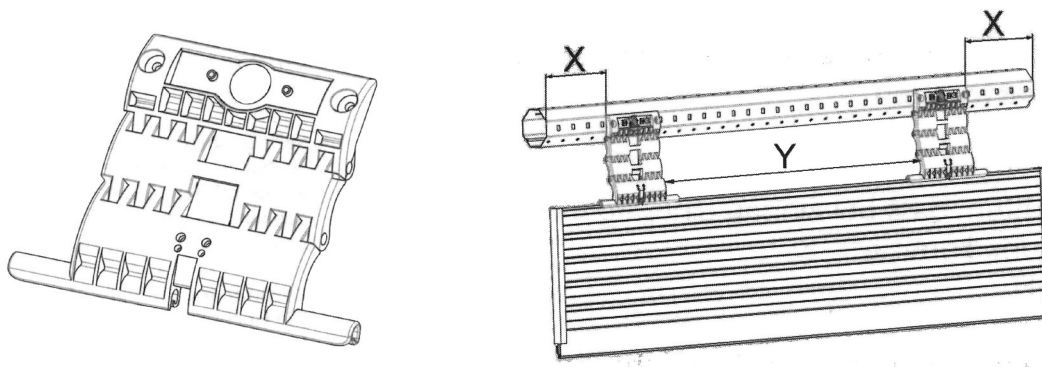

Talius supplies a special 6-32 x 1/4" screw to attach the hanger locks to the shaft. Make sure to install on the correct side of the shaft as shown below and **DO NOT** over-tighten. We recommend using a drill set to the lowest torque setting or tightening by hand.

Correct Side

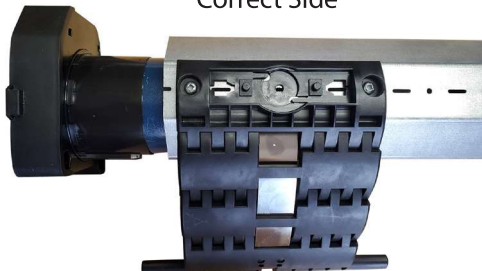

Wrong Side



Section 11

ACTIVATING ROLLSHUTTER STOPPERS

11.1) Rollshutter equipped with surface stoppers

Attach them now with the supplied bolts and washers in the pre-drilled locations.

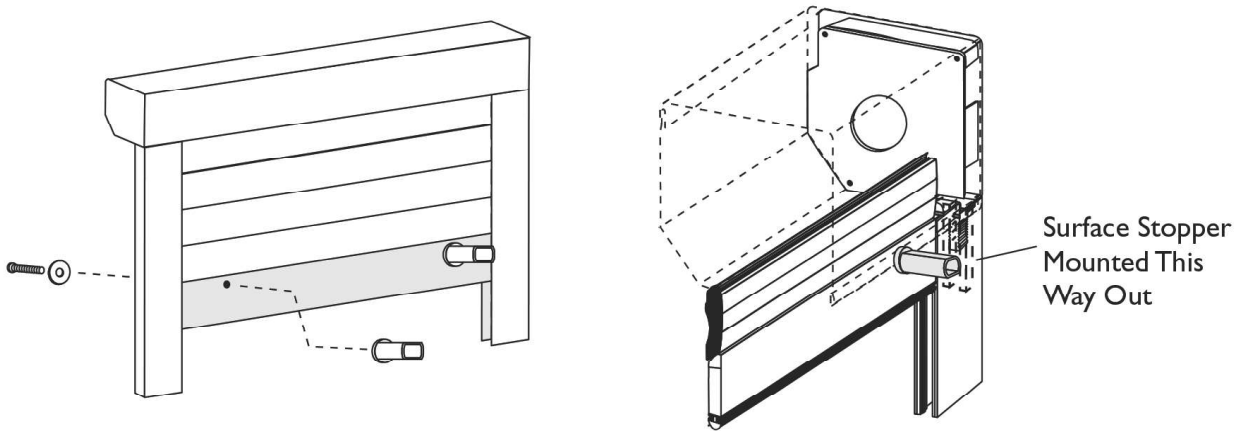

Section 12

SILL INSTALLATION

If the Rollshutter or Rollshutter has a natural sill to rest on or is mounted at the floor level such as in the case of a rolling door or many patio doors, proceed to the next section. Use the manual operator to lift the curtain halfway up. For electric Rollshutters use the tester cable switch. L-sill should be installed below the rails, U-sill should be installed between the rails. Install the sill with 2" - 3" (50 - 75mm) long screws. Space the screws every 16" (40cm) or less. If using a U-sill for extra security, drill a sufficient number of weep holes through the bottom for water/moisture drainage. This can also be requested of the manufacturer at time of ordering.

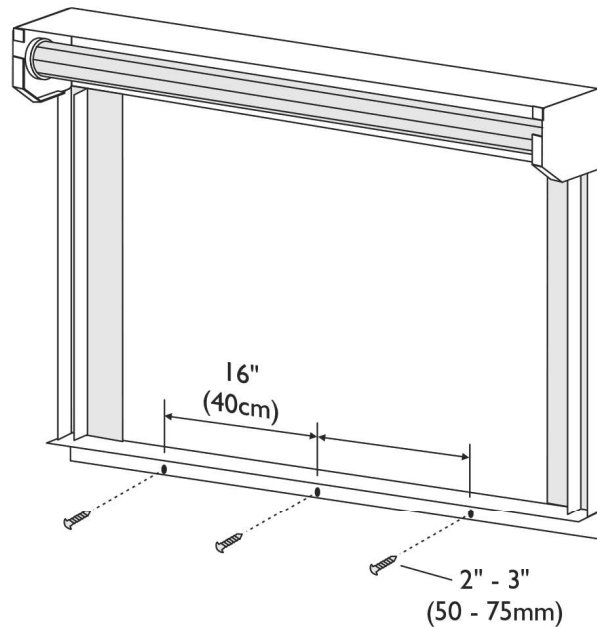

Section 13

LIMIT SETTING FOR MOTORIZED OPERATORS

This section shows the limit switch adjustment for motorized Rollshutters. If your unit is manually operated proceed to the next section.

13.1 a) Somfy RTS Motors

When you receive your Rollshutter with a Somfy RTS motor the unit will come with a pre-program transmitter in user mode. To adjust the limits follow the simple steps below. If you have a multi-channel transmitter, select the channel corresponding to the unit that you are adjusting and follow these steps. Which unit corresponds to which channel is chosen at the time of ordering. If you have more than one unit on a single channel, power must be disconnected to additional units so that only the unit being adjusted has power. After isolating a single unit, preform the limit adjustment steps below and repeat for each unit.

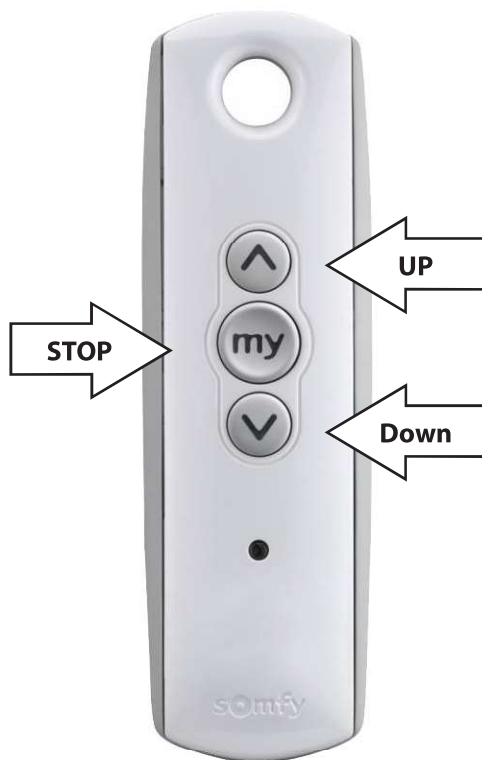

Telis 1 & 4



Decoflex 1 & 5

Step One: Adjusting the Upper Limit

- Move the motor to its current upper limit position and let it stop
- Press the **UP** and **DOWN** buttons simultaneously on the transmitter until the motor jogs, then release
- Adjust to a new upper limit position
- Press the **STOP** button until the motor jogs, then release
- Check that the limit is in the desired position

Step Two: Adjusting the Lower Limit

- Move the motor to its current lower limit position and let it stop
- Press the **UP** and **DOWN** buttons simultaneously on the transmitter until the motor jogs, then release
- Adjust to a new lower limit position
- Press the **STOP** button until the motor jogs, then release
- Check that the limit is in the desired position

13.1 b) **Standard Limit Motors**

General: Electrical Rollshutter units are operated by tubular motors housed inside the unit's shaft at one end. The motor can be located by looking for the wires leading to the Rollshutter unit. Each motor has two internal limit switches. The function of the "upper" limit switch is to cut off power to the motor when the unit has reached the completely rolled-up position. The function of the "lower" limit switch is to cut off power to the motor when the unit has reached the completely rolled-down position. Since every Rollshutter unit is different it is necessary to adjust the limit switches according to the following instructions.

Limit Setting Instructions Steps

1. Locate the Limit adjustment buttons on the head of the motor. (see diagrams below)
2. Using the tester cables or switch, operate the unit up until curtain stops at the temporary **UP** limit (set by Talius).
3. Unlock the **UP** limit switch on the motor by pressing the appropriate button down and releasing it. The button will stay pressed in.
4. Run curtain up to new desired **UP** limit and stop.
5. Press down and release the button again so that the button pops up. This will lock in the new **UP** limit position.
6. Run unit downwards until curtain stops at the **DOWN** limit (set by Talius) and adjust if necessary using the other limit adjustment button.
7. Unlock the **DOWN** limit switch on the motor by pressing the appropriate button down and releasing it. The button will stay pressed in.
8. Run curtain down to new desired **DOWN** limit and stop.
9. Press down and release the button again so that the button pops up. This will lock in the new **DOWN** limit position.
10. Test unit to ensure the unit stops automatically where you wish it to.

**UP
LIMIT**

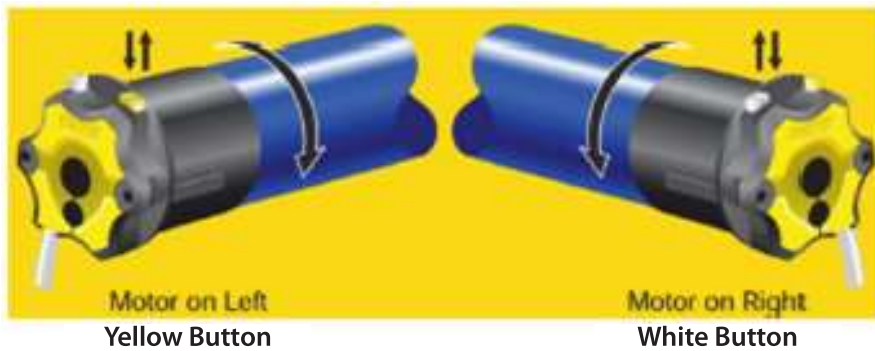

**DOWN
LIMIT**

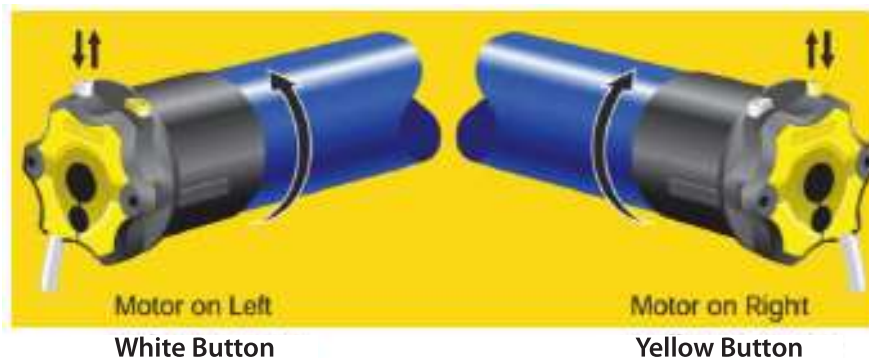

Section 13 • 13.1b (Continued)

Occasionally, the limit adjustment buttons are hidden on the back side of the motor from the installer. This sometimes must happen in order to locate the Manual override where the customer desires it to be. In these cases, Talius supplies metal brackets in which tabs are accessible to press and release the limit buttons as necessary. In these cases, you are pulling and releasing. The tabs are labeled "UP" and "DOWN" on the inside of the endplate for quick identification.



* image of limit brackets

13.2) General Notes For All Motor Types

Run the Rollshutter up and down at least twice. The limits take some setting into place and may move slightly during that procedure. The limits may need to be readjusted again slightly. After that is done, there will be no more adjustments necessary.

Common Problems and Solutions During Limit Setting for Rollshutters

Problem: The motor stops and will not move under any circumstances.

Explanation: The motor has overheated. The internal thermal protection switch has cut off power and will restore it automatically in 10 to 45 minutes, depending on the surrounding temperature. Motors are designed to run for short intervals only. During limit switch adjustments they tend to be operated almost continuously and can overheat. The motor is not harmed by being overheated. While waiting for the reset make sure that power to the motor has been shut off, or it may reactivate unexpectedly.

Problem: The limit switch stops the motor at a markedly different position (more than 1" or 25mm difference) every time it is checked. Trying to adjust it seems not to help. Sometimes it appears to be in order but a few days later the customer reports that it has moved again.

Explanation: The limit switch was slightly damaged during initial adjustment most commonly due to incorrect wiring. This problem will get worse with time. Eventually the limit will be lost altogether. The motor needs to be replaced. Contact the factory.

Problem: The rollshutter comes to a stop at the upper limit. Soon afterwards the click that the unit normally makes when it shuts off is heard, once or several times.

Explanation: A faulty brake in the motor lets the rollshutter slide down slightly, almost unnoticeably. The limit switch eventually gets released and supplies the motor with power, provided the tester cable or switching mechanism has remained switched in the "up" direction. The motor runs up momentarily until the limit switch cuts off power again. Then the cycle repeats. Contact the factory and request a new motor.

Section 13 • 13.2 (Continued)

Problem: The motor makes a grinding sound and/or it chatters when it reaches either of its limits.

Explanation: This is the case when the installation includes more than one motor connected to one switching mechanism and where the motors have been wired in parallel. Usually motors connected to one switch will experience capacitor feedback, unless the motors were specially designed for this type of hook-up and the hook-up is shown in the wiring diagram. Cut all power immediately. Hook up only one motor to one switching mechanism. Try again with the correct hook-up and verify that motors run properly now.

Note that it is quite probable that the limit switches and/or capacitors in the motors were damaged due to the initial faulty hook-up. Notify the factory of the incident and discuss the problem. In any case it is likely that these motors will fail in the future either by not running at all or losing one or both of their limit switches. Without limits, the customer may experience catastrophic destruction of the rollshutter units as the motors turn indefinitely. It is highly advisable to exchange the motors now in order to avoid very costly repairs later.

Section 14

LOCKS

If the Rollshutters were ordered with any type of manual locking systems read through this section. Otherwise proceed to the next section. Note that key switches for motorized Rollshutters are covered in the wiring diagrams available from Talius or from mytalius.com. If the unit was ordered with hanger locks the instructions for installation can be found in sections 7 and 10.

14.1 a) Manual Sliding Lock Bars

Manual slide locks are activated by sliding two metal bars into openings inside the guide rails when the Rollshutter is in the down position. If the Rollshutters are supplied with manual pull down handles install them on the bottom profile where convenient. The factory may already have done so.

Problem: The manual sliding locks do not lock the Rollshutter curtain down.

Solution: The guide rails may have been installed upside down. Check if there is a slot in the bottom of the guide rail's channel. If it is on top instead, remove the guide rail and turn it upside down. Note that some guide rails are not symmetrical and therefore it may be necessary to interchange right with left guide rail.

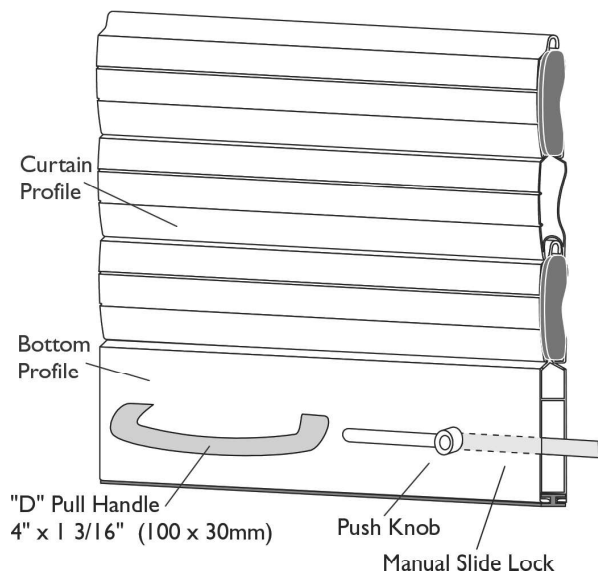

Section 14 • 14.1 (Continued)

14.1 b) Centre Key Locks

Centre Key Locks are operated manually with a key activating metal lock bars into a slot inside each guide rail's channel. There is one key lock activating a lock bar on both sides of the curtain. The lock may be operated from inside or outside the Rollshutter. If the Rollshutter is supplied with pull down handles mount these on the bottom profile where convenient. The factory may already have done so.

Problem: The centre key locks do not lock the Rollshutter curtain down.

Solution: i) The guide rails may have been installed upside down. Check if there is a slot in the bottom of the guide rail's channel. If it is on top instead, remove the guide rail and turn it upside down. Note that some guide rails are not symmetrical and therefore it may be necessary to interchange right with left guide rail.

ii) The bottoms of the guide rails may have been spaced apart too far during installation. Measure the distance between the guide rails on the bottom and compare it to the measurement on top where they meet the panel box. If the bottom dimension is larger than the top dimension move the guide rails closer together

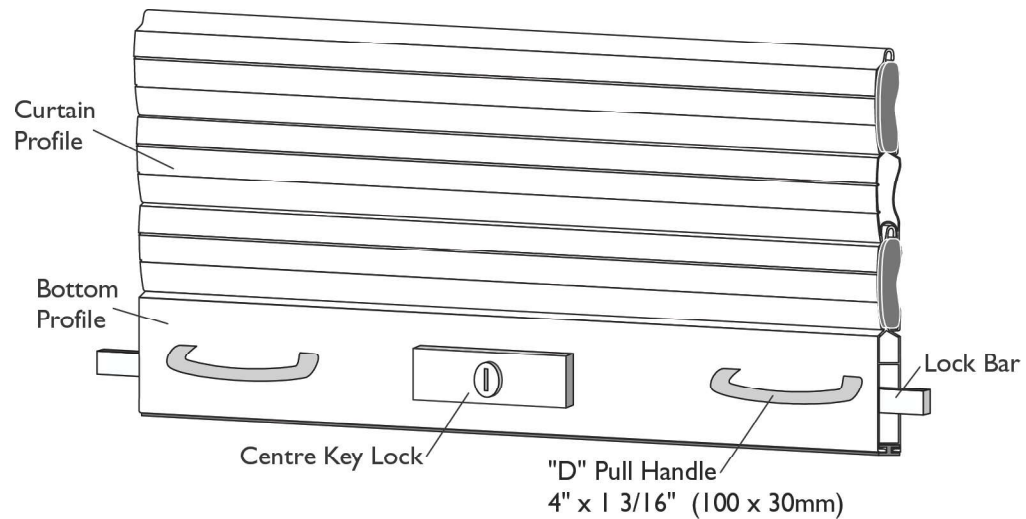

Section 15

FINISHING

- 15.1) Pull off the protective cover foils from the panel box top and bottom and other parts that may be covered. Slip the lip of the panel box lid into the corresponding groove of the panel box top and attach it with four 3/8" (10mm) long screws. If space requirements do not permit the use of all four screws, choose either only the two lower ones or the two upper ones.
- 15.2) **PVC Screw Caps**
Insert the PVC screw caps over the mounting holes in the one-piece guide rails (Pro or SV Series)
- 15.3) **Caulking**
Caulking around the top of the panel box and guild rails will help to prevent water from penetrating behind the Rollshutter and to ensure a clean finished appearance.
- 15.4) Wipe clean as necessary.

The installation is now complete!

Every installation is different and there may be some questions. Do not hesitate to call us from site for support, 1-800-665-5550. A properly installed Rollshutter will operate trouble-free for many years to come.

WARRANTY REGISTRATION

Please have your customer visit www.talius.com to register their warranty. They will receive a complete warranty copy via email after registering. If preferred, the Talius Dealer can register the warranty on the customer's behalf.

APPENDIX A

SAFE RAIL SERVICING

Follow these instructions if the two-part safe rail needs to be disassembled for servicing. Some customers prefer to simply cut the existing rail cap off by slicing it down the center of the rounded face with a cutting disc and then supplying a new cap once the service is complete. An option to this is detailed below. You can also contact the factory to discuss other options.

Order a Talius safe rail tool or use a similar existing tool. Ensure that any tool surface contacting an out-side surface of the guide rail is adequately covered with a non-marring material.

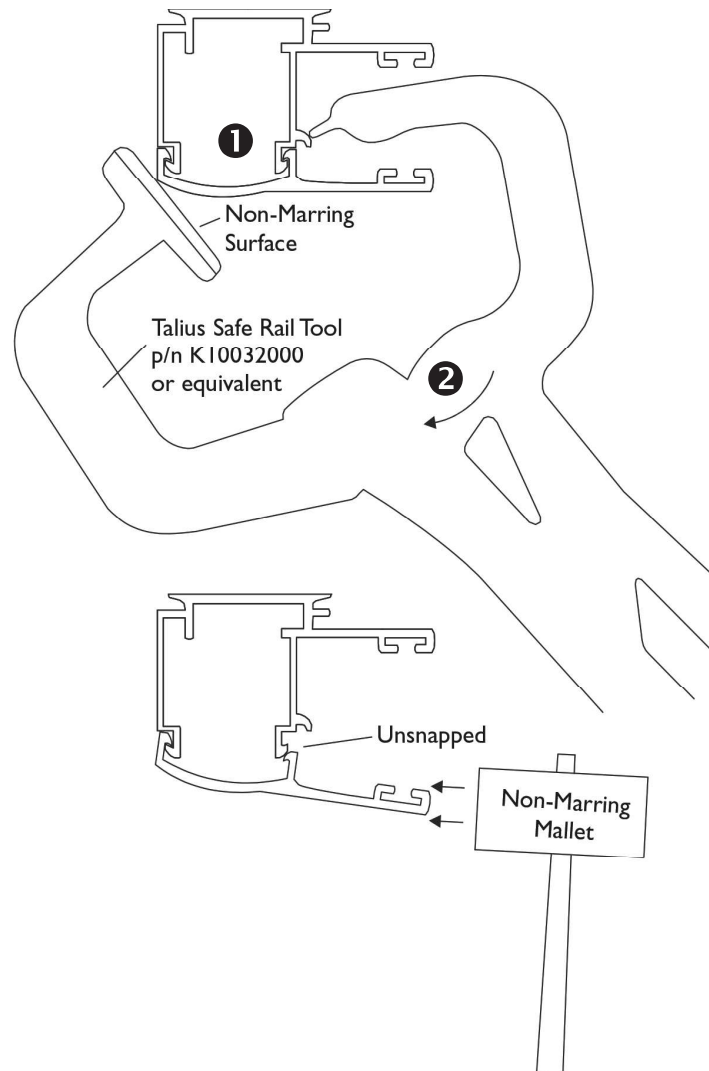

Start at the bottom of the guide rail. Using the safe rail tool, compress the safe rail mount

- ① So that the safe rail cap becomes disengaged.
- ② Use a twisting motion to disengage the inner snap and begin pulling the cap off.

Continue working towards the top of the rail until the safe rail cap is completely unsnapped from the safe rail mount. Use a mallet with a soft, non-marring head to finish disengaging the safe rail cap.



HEAD OFFICE/MANUFACTURING FACILITY

PO Box 3279, 5501 - 46 Ave SE
Salmon Arm, BC, Canada V1E 4S1
TEL 250.832.7777 ■ FAX 250.832.8577
TOLL FREE 800.665.5550
EMAIL info@talius.com

VANCOUVER BRANCH OFFICE

#4, 200 Golden Drive
Coquitlam, BC, Canada V3K 6M8
TEL 604.468.7655 ■ FAX 604.468.7656
EMAIL taliusvancouver@talius.com